



Dough Mixers  
42 liter Spiral Dough Kneader, 2  
Speeds, Removable Bowl, Tilting Head

ITEM # \_\_\_\_\_

MODEL # \_\_\_\_\_

NAME # \_\_\_\_\_

SIS # \_\_\_\_\_

AIA # \_\_\_\_\_



**602358 (DSKTH42L)**

42 Lt spiral Dough Kneader, 2 speed, Removable Bowl, Tilting Head,

Short Form Specification

Item No. \_\_\_\_\_

2 speed spiral dough kneader on wheels, with tilting head and motorized, removable bowl. Ideal for pizzeria, bakeries and pastries. Ingredients are kneaded with a stainless steel spiral mixer arm synchronised with bowl rotation (motorized not removable bowl). Body is in painted steel, the 42 Lt capacity bowl, spiral mixer arm and dough breaker pin are in stainless steel. The safety screen allows ingredients to be added without stopping. Equipped with low voltage control panel with on/off switch, speed selection and timer (up to 30 min) or continuous mode. Safety device to stop the machine when the protection screen is opened. Tool speed: 84 and 168 rpm; bowl speed: 13 and 26 rpm. Maximum dough capacity: 33 kg per cycle (max. flour 20.6 kg/cycle), with 60% hydration.

Main Features

- Spiral dough kneader with tilting head and motorized, removable bowl.
- Maximum kneading capacity 33 kg per cycle (max. flour 20.6 kg/cycle), with 60% hydration.
- Ideal for kneading pizza dough, bread or similar dough.
- Two speed kneading for faster cycles (tool speed: 84 and 168 rpm; bowl speed: 13 and 26 rpm).
- Central column for optimal kneading.
- Stainless steel (AISI304) squared dough breaker bar for fast and even kneading results
- Transparent protective screen to reduce flour dust release in the work area during kneading (EU EN453:2014) and to prevent dough contaminations.
- Minimum kneading capacity: 19 kg/cycle, with 60% hydration.
- Safety device stops the appliance if the cover is openend.
- Equipped with 4 wheels, of which 2 with brakes, allowing to easily move the appliance for storage or cleaning.
- The appliance fits under standard kitchen worktops (see installation drawing).

Construction

- Constructed in painted steel.
- AISI304 stainless steel bowl, spiral hook and dough breaker bar.
- Power: 1100 watts.
- Control panel with on/off switch, speed selection and timer.
- Analogic timer up to 30 minutes or continuous mode.
- IP54 protected control panel.
- IP23 for the appliance overall.
- Additional bowl available as optional accessory.

Included Accessories

- 1 of 42lt s/s bowl for PNC 653893 tilting head spiral dough kneader

Optional Accessories

APPROVAL: \_\_\_\_\_



## Dough Mixers 42 liter Spiral Dough Kneader, 2 Speeds, Removable Bowl, Tilting Head

Side

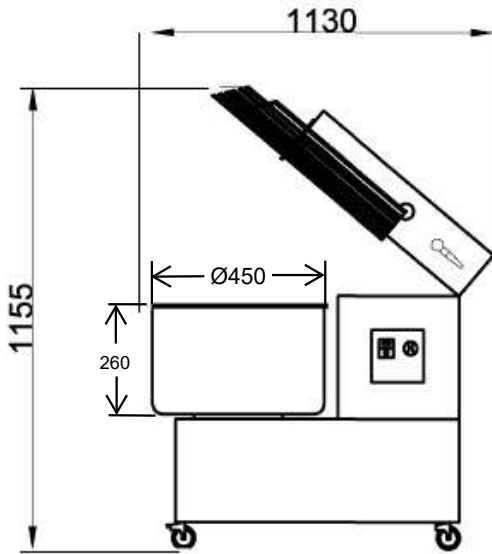

Rear side

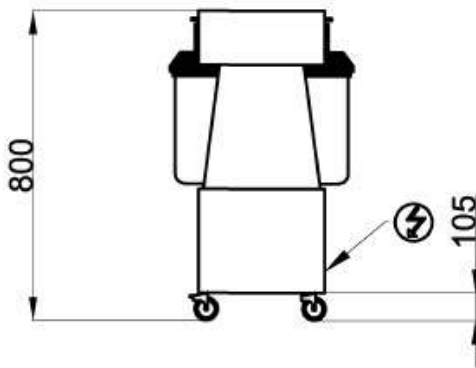

EI = Electrical inlet  
(power)

Top

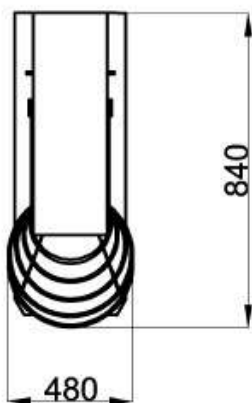

Electric

**Supply voltage:** 380-415 V/3 ph/50 Hz  
**Total Watts:** 3 kW

Capacity:

**Maximum kneading (60% hydration):** 33 kg/Cycle

Key Information:

**External dimensions, Width:** 480 mm

**External dimensions, Depth:** 840 mm

**External dimensions, Height:** 800 mm

**Shipping weight:** 129 kg

**Bowl capacity:** 42 lt



Dough Mixers  
42 liter Spiral Dough Kneader, 2 Speeds, Removable Bowl, Tilting Head  
The company reserves the right to make modifications to the products without prior notice. All information correct at time of printing.

2026.04.21